

8.625"

3.64375"

9.8"

6.15625"

HIGHLIGHTS OF PRESCRIBING INFORMATION

These highlights do not include all the information needed to use POTASSIUM CHLORIDE EXTENDED-RELEASE CAPSULES safely and effectively. See full prescribing information for POTASSIUM CHLORIDE EXTENDED-RELEASE CAPSULES.

POTASSIUM CHLORIDE extended-release capsules, for oral use Initial U.S. Approval: 1948

INDICATIONS AND USAGE

Potassium chloride extended-release capsules contain potassium chloride, a potassium salt indicated for the treatment and prophylaxis of hypokalemia with or without metabolic alkalosis, in patients for whom dietary management with potassium-rich foods or diuretic dose reduction is insufficient. (1)

DOSAGE AND ADMINISTRATION

Monitor serum potassium and adjust dosage accordingly (2.1) If serum potassium concentration is <2.5 mEq/L, use intravenous potassium instead of oral supplementation. (2.1)

Treatment of hypokalemia:

- Adults: Typical doses range from 40-100 mEq/day in 2-5 divided doses; limit doses to 40 mEq per dose. (2.2) Pediatric patients: 2-4 mEq/kg/day in divided doses not to exceed 1 mEq/kg as a single dose or 20 mEq, whichever is lower; if deficits are severe or ongoing losses are great, consider intravenous therapy. (2.3)

Maintenance or Prophylaxis of hypokalemia:

- Adults: Typical dose is 20 mEq per day (2.2) Pediatric patients: Typical dose is 1 mEq/kg/day. (2.3)

FULL PRESCRIBING INFORMATION: CONTENTS*

- 1 INDICATIONS AND USAGE
2 DOSAGE AND ADMINISTRATION
2.1 Administration and Monitoring
2.2 Adult Dosing
2.3 Pediatric Dosing
3 DOSAGE FORMS AND STRENGTHS
4 CONTRAINDICATIONS
5 WARNINGS AND PRECAUTIONS
5.1 Gastrointestinal Adverse Reactions
6 ADVERSE REACTIONS
7 DRUG INTERACTIONS
7.1 Amiloride and Triamterene
7.2 Renin-Angiotensin-Aldosterone Inhibitors
7.3 Nonsteroidal Anti-inflammatory Drugs (NSAIDs)
8 USE IN SPECIFIC POPULATIONS
8.1 Pregnancy
8.2 Lactation

FULL PRESCRIBING INFORMATION

1 INDICATIONS AND USAGE

Potassium chloride extended-release capsules are indicated for the treatment and prophylaxis of hypokalemia in adults and children with or without metabolic alkalosis, in patients for whom dietary management with potassium-rich foods or diuretic dose reduction is insufficient.

2 DOSAGE AND ADMINISTRATION

2.1 Administration and Monitoring

If serum potassium concentration is <2.5 mEq/L, use intravenous potassium instead of oral supplementation.

Monitoring

Monitor serum potassium and adjust dosages accordingly. Monitor serum potassium periodically during maintenance therapy to ensure potassium remains in desired range.

The treatment of potassium depletion, particularly in the presence of cardiac disease, renal disease, or acidosis requires careful attention to acid-base balance, volume status, electrolytes, including magnesium, sodium, chloride, phosphate, and calcium, electrocardiograms and the clinical status of the patient. Correct volume status, acid-base balance and electrolyte deficits as appropriate.

Administration

Take with meals and with a full glass of water or other liquid. Do not take on an empty stomach because of the potential for gastric irritation [see Warnings and Precautions (5.1)].

Patients who have difficulty swallowing capsules may sprinkle the contents of the capsule onto a spoonful of soft food. The soft food, such as applesauce or pudding, should be swallowed

DOSAGE FORMS AND STRENGTHS

- Extended-release capsules: 600 mg (8mEq) and 750 mg (10 mEq)

CONTRAINDICATIONS

- Concomitant use with triamterene and amiloride. (4)

WARNINGS AND PRECAUTIONS

- Gastrointestinal Irritation: Take with meals (5.1)

ADVERSE REACTIONS

Most common adverse reactions are nausea, vomiting, flatulence, abdominal pain/discomfort, and diarrhea. (6)

To report SUSPECTED ADVERSE REACTIONS, contact the manufacturer Adare at 1-877-731-5116, or FDA at 1-800-FDA-1088 or http://www.fda.gov/medwatch.

DRUG INTERACTIONS

- Triamterene and amiloride: Concomitant use is contraindicated (7.1) Renin-angiotensin-aldosterone inhibitors: Monitor for hyperkalemia (7.2) Nonsteroidal Anti-inflammatory drugs (NSAIDs): Monitor for hyperkalemia (7.3)

USE IN SPECIFIC POPULATIONS

- Cirrhosis: Initiate therapy at the low end of the dosing range (8.6) Renal Impairment: Initiate therapy at the low end of the dosing range (8.7)

See 17 for PATIENT COUNSELING INFORMATION.

Revised: 10/2019

- 8.4 Pediatric Use
8.5 Geriatric Use
8.6 Cirrhotics
8.7 Renal Impairment

10 OVERDOSAGE

- 10.1 Symptoms
10.2 Treatment

11 DESCRIPTION

12 CLINICAL PHARMACOLOGY

- 12.1 Mechanism of Action
12.3 Pharmacokinetics

16 HOW SUPPLIED/STORAGE AND HANDLING

17 PATIENT COUNSELING INFORMATION

*Sections or subsections omitted from the full prescribing information are not listed.

immediately without chewing and followed with a glass of water or juice to ensure complete swallowing of the microcapsules. Do not add to hot foods. Any microcapsule/food mixture should be used immediately and not stored for future use.

2.2 Adult Dosing

Dosage must be adjusted to the individual needs of each patient. Dosages greater than 40 mEq per day should be divided such that no more than 40 mEq is given in a single dose.

Treatment of hypokalemia: Typical dose range is 40-100 mEq per day.

Maintenance or Prophylaxis: Typical dose is 20 mEq per day.

2.3 Pediatric Dosing

Pediatric patients aged birth to 16 years old: Dosage must be adjusted to the individual needs of each patient. Do not exceed as a single dose 1 mEq/kg or 20 mEq, whichever is lower.

Treatment of hypokalemia: The recommended initial dose is 2 to 4 mEq/kg/day in divided doses. If deficits are severe or ongoing losses are great, consider intravenous therapy.

Maintenance or Prophylaxis: Typical dose is 1 mEq/kg/day.

3 DOSAGE FORMS AND STRENGTHS

600 mg (8 mEq): White to ivory opaque capsules printed with "102" in black ink on the cap.

750 mg (10 mEq): Light blue opaque capsules printed with "103" in black ink on the cap.

4 CONTRAINDICATIONS

Potassium chloride extended-release capsules are contraindicated in patients on amiloride or triamterene.

5 WARNINGS AND PRECAUTIONS

5.1 Gastrointestinal Adverse Reactions

Solid oral dosage forms of potassium chloride can produce ulcerative and/or stenotic lesions of the gastrointestinal tract, particularly if the drug is in contact with the gastrointestinal mucosa for a prolonged period of time. Consider the use of liquid potassium in patients with dysphagia, swallowing disorders, or severe gastrointestinal motility disorders.

If severe vomiting, abdominal pain, distention, or gastrointestinal bleeding occurs, discontinue potassium chloride extended-release capsules and consider possibility of ulceration, obstruction or perforation.

Potassium chloride extended-release capsules should not be taken on an empty stomach because of its potential for gastric irritation [see Dosage and Administration (2.1)].

6 ADVERSE REACTIONS

The following adverse reactions have been identified with use of oral potassium salts. Because these reactions are reported voluntarily from a population of uncertain size, it is not always possible to reliably estimate their frequency or establish a causal relationship to drug exposure.

The most common adverse reactions to oral potassium salts are nausea, vomiting, flatulence, abdominal pain/discomfort, and diarrhea.

There have been reports of hyperkalemia and of upper and lower gastrointestinal conditions including obstruction, bleeding, ulceration, and perforation.

Skin rash has been reported rarely.

7 DRUG INTERACTIONS

7.1 Amiloride and Triamterene

Use with triamterene or amiloride can produce severe hyperkalemia. Concomitant use is contraindicated [see Contraindications (4)].

7.2 Renin-Angiotensin-Aldosterone Inhibitors

Drugs that inhibit the renin-angiotensin-aldosterone system (RAAS) including angiotensin converting enzyme (ACE) inhibitors, angiotensin receptor blockers (ARBs), spironolactone, eplerenone, or aliskiren produces potassium retention by inhibiting aldosterone production. Closely monitor potassium in patients taking drugs that inhibit RAAS.

7.3 Nonsteroidal Anti-Inflammatory Drugs (NSAIDs)

NSAIDs may produce potassium retention by reducing renal synthesis of prostaglandin E and impairing the renin-angiotensin system. Closely monitor potassium in patients taking NSAIDs.

8 USE IN SPECIFIC POPULATIONS

8.1 Pregnancy

Risk Summary

There are no human data related to use of potassium chloride extended-release capsules during pregnancy and animal reproductive studies have not been conducted. Potassium supplementation that does not lead to hyperkalemia is not expected to cause fetal harm.

The background risk for major birth defects and miscarriage in the indicated population is unknown. All pregnancies have a background risk of birth defect, loss, or other adverse outcomes. In the U.S. general population, the estimated background risk of major birth defects and miscarriage in clinically recognized pregnancies is 2-4% and 15-20%, respectively.

8.2 Lactation

Risk Summary

The normal potassium ion content of human milk is about 13 mEq per liter. Since oral potassium becomes part of the body potassium pool, as long as body potassium is not excessive, the contribution of potassium chloride supplementation should have little or no effect on the level in human milk.

8.4 Pediatric Use

Clinical trial data from published literature have demonstrated the safety and effectiveness of potassium chloride in children with diarrhea and malnutrition from birth to 18 years.

8.5 Geriatric Use

Clinical studies of potassium chloride did not include sufficient numbers of subjects aged 65 and over to determine whether they respond differently from younger subjects. Other reported clinical experience has not identified differences in responses between the elderly and younger patients. In general, dose selection for an elderly patient should be cautious, usually starting at the low end of the dosing range, reflecting the greater frequency of decreased hepatic, renal, or cardiac function, and of concomitant disease or other drug therapy.



Phone: 919.553.4113 • Fax: 919.553.2581

Independent Carton Group

Structure: CC12044
File Name: 040-T-00616 Front
Date: 21 OCT 2019
Graphic Tech.: JS

3C-06

Die Line (does not print)

Black

Please check proof closely for accuracy of copy, color separations, spelling, special characters, and barcodes. Spot colors are not verified. Spot colors will be matched on press to customer approved L*A*B* value or Digital values from Pantone Library.

Customer acknowledges that If permission has been given to 3C Packaging, Inc. (3C) to typeset, change, or otherwise alter the art file(s) referenced in this document or communication. 3C will make every effort to ensure any reproduction or changes in the art files are accurate and do not contain any misinformation, misspellings or errors. However, it is the responsibility of Customer to review every proof for accuracy, misinformation, and misspellings. Customer acknowledges that any liability arising out of any inaccuracies, misinformation, misspellings or any other errors as a result of changes made by 3C to the art files are limited to the cost of the product that 3C provided to Customer.

Prints Head To Head

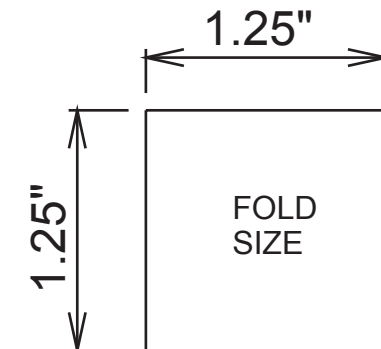

8.625"

9.8"

This drug is known to be substantially excreted by the kidney, and the risk of toxic reactions to this drug may be greater in patients with impaired renal function. Because elderly patients are more likely to have decreased renal function, care should be taken in dose selection, and it may be useful to monitor renal function.

8.6 Cirrhotics

Based on published literature, the baseline corrected serum concentrations of potassium measured over 3 hours after administration in cirrhotic subjects who received an oral potassium load rose to approximately twice that of normal subjects who received the same load. Patients with cirrhosis should usually be started at the low end of the dosing range, and the serum potassium level should be monitored frequently [see *Clinical Pharmacology* (12.3)].

8.7 Renal Impairment

Patients with renal impairment have reduced urinary excretion of potassium and are at substantially increased risk of hyperkalemia. Patients with impaired renal function, particularly if the patient is on RAAS inhibitors or nonsteroidal anti-inflammatory drugs, should usually be started at the low end of the dosing range because of the potential for development of hyperkalemia [see *Drug Interactions* (7.2, 7.3)]. The serum potassium level should be monitored frequently. Renal function should be assessed periodically.

10 OVERDOSAGE

10.1 Symptoms

The administration of oral potassium salts to persons with normal excretory mechanisms for potassium rarely causes serious hyperkalemia. However, if excretory mechanisms are impaired, potentially fatal hyperkalemia can result.

Hyperkalemia is usually asymptomatic and may be manifested only by an increased serum potassium concentration (6.5-8.0 mEq/L) and characteristic electrocardiographic changes (peaking of T-waves, loss of P-waves, depression of S-T segment, and prolongation of the QT-interval). Late manifestations include muscle paralysis and cardiovascular collapse from cardiac arrest (9-12 mEq/L).

10.2 Treatment

Treatment measures for hyperkalemia include the following:

1. Monitor closely for arrhythmias and electrolyte changes.
2. Eliminate foods and medications containing potassium and any agents with potassium-sparing properties such as potassium-sparing diuretics, ARBs, ACE inhibitors, NSAIDs, certain nutritional supplements, and many others.
3. Administer intravenous calcium gluconate if the patient is at no risk or low risk of developing digitalis toxicity.
4. Administer 300 to 500 mL/hr of 10% dextrose solution containing 10 to 20 units of crystalline insulin per 1,000 mL.
5. Correct acidosis, if present, with intravenous sodium bicarbonate.
6. Use exchange resins, hemodialysis, or peritoneal dialysis.

In patients who have been stabilized on digitalis, too rapid a lowering of the serum potassium concentration can produce digitalis toxicity.

The extended-release feature means that absorption and toxic effects may be delayed for hours. Consider standard measures to remove any unabsorbed drug.

11 DESCRIPTION

Potassium chloride extended-release capsules, USP, are an oral dosage form of microencapsulated potassium chloride containing 600 mg and 750 mg of potassium chloride, USP, equivalent to 8 mEq and 10 mEq of potassium, respectively.

The chemical name of the active ingredient is potassium chloride and the structural formula is KCl. It has a molecular mass of 74.55. Potassium chloride, USP, occurs as a white granular powder or as colorless crystals. It is odorless and has a saline taste. Its solutions are neutral to litmus. It is freely soluble in water and insoluble in alcohol.

Inactive ingredients: ethylcellulose, gelatin, magnesium stearate, sodium lauryl sulfate, titanium dioxide and edible black ink. The 10 mEq capsules also contain black iron oxide, FD&C blue No.1 and FD&C red No.3.



12 CLINICAL PHARMACOLOGY

12.1 Mechanism of Action

The potassium ion (K⁺) is the principal intracellular cation of most body tissues. Potassium ions participate in a number of essential physiological processes, including the maintenance of intracellular tonicity; the transmission of nerve impulses; the contraction of cardiac, skeletal, and smooth muscle; and the maintenance of normal renal function.

The intracellular concentration of potassium is approximately 150 to 160 mEq per liter. The normal adult plasma concentration is 3.5 to 5 mEq per liter. An active ion transport system maintains this gradient across the plasma membrane.

Potassium is a normal dietary constituent and under steady-state conditions the amount of potassium absorbed from the gastrointestinal tract is equal to the amount excreted in the urine. The usual dietary intake of potassium is 50 to 100 mEq per day.

12.3 Pharmacokinetics

Each crystal of KCl is microencapsulated and allows for the controlled release of potassium and chloride ions over an eight- to ten-hour period.

Specific Populations

Cirrhotics

Based on published literature, the baseline corrected serum concentrations of potassium measured over 3 hours after administration in cirrhotic subjects who received an oral potassium load rose to approximately twice that of normal subjects who received the same load.

16 HOW SUPPLIED/STORAGE AND HANDLING

Potassium chloride extended-release capsules, USP, 8 mEq and 10 mEq contain 600 mg and 750 mg of potassium chloride (equivalent to 8 mEq and 10 mEq, respectively).

Table 1: How Supplied

Dose	Color	Printing	NDC#: 63304 -xxx-xx	
			Bottle Count	
			100	500
600 mg (8 mEq)	white to ivory	102	078-01	—
750 mg (10 mEq)	light blue	103	090-01	090-05

Store at 20° to 25°C (68°-77°F); excursions are permitted to 15° to 30°C (59°-86°F) [see USP *Controlled Room Temperature*.]

Dispense in tight, light-resistant container as defined in the USP, with a child-resistant closure.

Rx only

17 PATIENT COUNSELING INFORMATION

- Inform patients to take each dose with meals and with a full glass of water or other liquid.
- Advise patients to seek medical attention if tarry stools or other evidence of gastrointestinal toxicity is noticed.

Manufactured By:
Adare Pharmaceuticals, Inc.
Vandalia, OH 45377

Distributed By:
Sun Pharmaceutical Industries, Inc.
Cranbury, NJ 08512

Iss. 10/2019

Phone: 919.553.4113 • Fax: 919.553.2581

Independent Carton Group

Structure: CC12044
 File Name: 040-T-00616 Back
 Date: 21 OCT 2019
 Graphic Tech.: JS 3C-06

Die Line (does not print)

Black

Please check proof closely for accuracy of copy, color separations, spelling, special characters, and barcodes. Spot colors are not verified. Spot colors will be matched on press to customer approved L*A*B* value or Digital values from Pantone Library. Customer acknowledges that if permission has been given to 3C Packaging, Inc. (3C) to typeset, change, or otherwise alter the art file(s) referenced in this document or communication. 3C will make every effort to ensure any reproduction or changes in the art files are accurate and do not contain any misinformation, misspellings or errors. **However, it is the responsibility of Customer to review every proof for accuracy, misinformation, and misspellings. Customer acknowledges that any liability arising out of any inaccuracies, misinformation, misspellings or any other errors as a result of changes made by 3C to the art files are limited to the cost of the product that 3C provided to Customer.**

Prints Head To Head

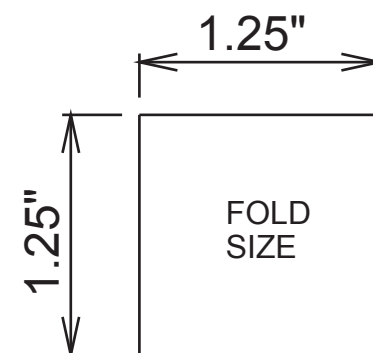



3C! Packaging
 QC
 1000 CCC Drive
 Clayton, NC 27520
 U.S.A.



Barcode report

Item: 040-T00616 Inspection: 1
 :
 Date: 10/21/2019 Time: 9:43:09 AM
 Verifier: proofiler operator

Used parameter set:		PDF to PDF	
Software version:	3.4.5 (Build 39336)		
Barcode parameters:			
Required grade:	C	Regard traditional:	disabled

Result:			
Number of items:	OK: 1	Defective: 0	Count: 1
Barcode:	OK: 2	Defective: 0	Count: 2

Barcode:				
Item - Code		Type	Code	Grade
1 - 1	Template		emp t y	OK
1 - 1	Sample	Code 128	10 / 2019	A - OK
1 - 2	Template		emp t y	OK
1 - 2	Sample	Code 128	0616	A - OK

Comment :

The item(s) depicted on the following page(s) of this report have been inspected using automatic inspection equipment.

Sign: _____



3C! Packaging
 QC
 1000 CCC Drive
 Clayton, NC 27520
 U.S.A.



Barcode report

Item: 040-T00616 Inspection: 1
 :
 Date: 10/21/2019 Time: 9:45:41 AM
 Verifier: proofiler operator

Used parameter set:		PDF to PDF	
Software version:	3.4.5 (Build 39336)		
Barcode parameters:			
Required grade:	C	Regard traditional:	disabled

Result:			
Number of items:	OK: 1	Defective: 0	Count: 1
Barcode:	OK: 1	Defective: 0	Count: 1

Barcode:				
Item - Code		Type	Code	Grade
1 - 1	Template		emp t y	OK
1 - 1	Sample	Code 128	0616	A - OK

Comment :

The item(s) depicted on the following page(s) of this report have been inspected using automatic inspection equipment.

Sign: _____